

Compact Sandwich Prep Tables/ Self-Contained



Model KUST4818
(shown with optional casters)



Stainless Exterior,
Anodized Aluminum Interior

27", 32", 48", 60" & 72" Wide Models

27" Wide 6 Pan Model	KUST276
27" Wide 9 Pan Model	KUST279
32" Wide 8 Pan Model	KUST328
32" Wide 12 Pan Model	KUST3212
48" Wide 8 Pan Model	KUST488
48" Wide 12 Pan Model	KUST4812
48" Wide 18 Pan Model	KUST4818
60" Wide 12 Pan Model	KUST6012
60" Wide 24 Pan Model	KUST6024
72" Wide 12 Pan Model	KUST7212
72" Wide 18 Pan Model	KUST7218
72" Wide 24 Pan Model	KUST7224
72" Wide 30 Pan Model	KUST7230

Kairak's durable, high performance, sandwich prep tables provide a high quality/high value alternative to the all too common commodity types in today's market.

Any comparison between prep tables should start with performance, and Kairak really does the job. Not only do they all meet the NSF 7 Standard, but do so under real world conditions, even when using 6" deep pans! A Kairak exclusive.

Truly front breathing, their design allows for "zero-clearance" installation. As a result they can be placed right up against the back wall and alongside other kitchen equipment, saving valuable floor space.

Standard Product Features

- High Quality Stainless Steel Exterior Top, Sides & Door(s)
- Durable, Corrosion Resistant Anodized Aluminum Interior
- Provides NSF Standard 7 Performance, Even When Using 6" Deep Pans - A Kairak Exclusive
- Front Breathing Self-Contained Refrigeration System
- Standard Work Height 36-1/4" (see "optional accessory kits for lower height casters to meet ADA requirements or provide lower work heights).
- Environmentally Friendly R-134a Refrigerant
- Top Cut-Outs Accommodate Sixth Size Pans (divider bars and 4" deep plastic sixth size pans provided)
- Reinforced Pan Ledge (holds pans securely leveled, year after year)
- Stainless Steel Insulated Pan Lid with Two Open Positions
- Reversible, Full Length White Nylon Cutting Board
- Self-Closing Stainless Steel Doors With Convenient Stay Open Feature @ 105 Degrees
- Metal Door Handles
- Anodized Aluminum Interior Door Liners
- Interior Mounted Thermometer
- Two (2) Powder Coated Steel Shelves Per Door, Mounted On Adjustable Pilasters
- Automatic Non-Electric Condensate Evaporator
- Magnetic Snap-In Door Gaskets
- 8' Cord & Plug Attached
- Set of Four (4) 6" High Adjustable Legs (6 for 60" & 72" models)
- Three Year Parts And Labor Warranty
- Five Year Compressor Warranty

Optional Accessory Kits*

- **CASTER 5SET4** (four 6" high casters for 27", 32" & 48" models)
- **CASTER 5SET6** (six 6" high casters for 60" & 72" models)
- **CASTER SET4IN** (four 4" high casters for 27", 32" & 48" models)
- **CASTER 60SET3** (six 4" high casters for 60" & 72" models)
- **CASTER SET3IN** (four 3-1/2" high casters for 27", 32" & 48" models)
- **CASTER SET4** (six 3-1/2" high casters for 60" & 72" models)
- **CASTER SET2IN** (four 2-1/2" high casters for 27" models)
- **SHELF CPW1** (additional shelf for all 27" models)
- **SHELF CPW2** (additional shelf for all 32" models)
- **SHELF48 UPPER** (upper shelf for all 48" models)
- **SHELF48 LOWER** (lower shelf for all 48" models)
- **SHELF60 UPPER** (upper shelf for all 60" models)
- **SHELF60 LOWER** (lower shelf for all 60" models)
- **SHELF72 UPPER** (upper shelf for all 72" models)
- **SHELF72 LOWER** (lower shelf for all 72" models)

*All optional accessory kits are shipped separately for field installation.

Factory Installed Options

- Stainless Steel Finished Back
- Other Door Hingings



Listed by Underwriters Laboratories Inc., to U.S. and Canadian safety standards and NSF International in accordance with ANSI/NSF7.

Approval: _____

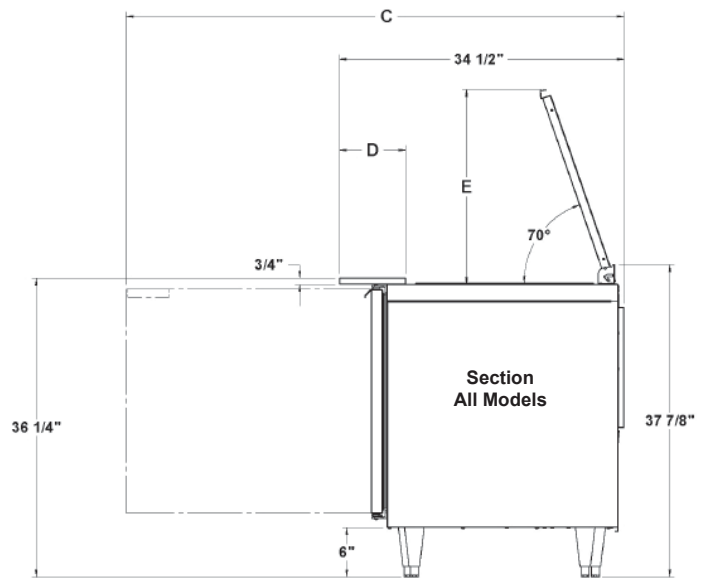
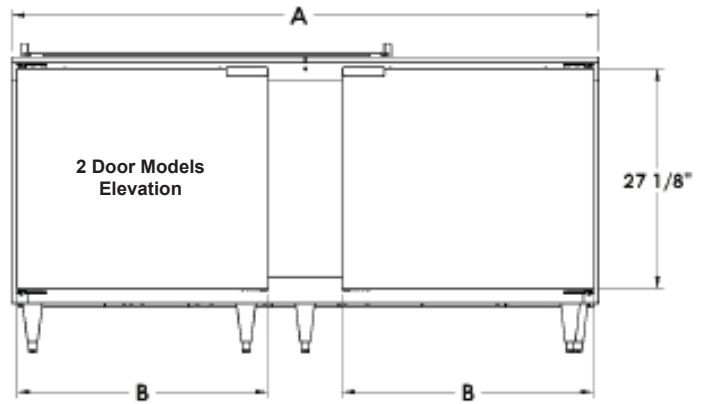
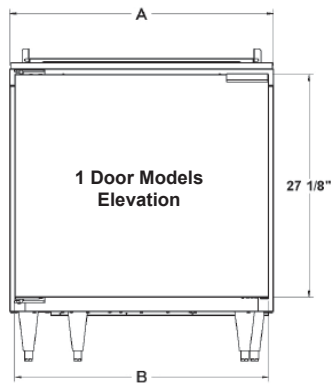

Cabinet Dimensional Data											
Model	Storage cu. ft.	# Of 1/6 size pans top	A Width - cabinet	B Width - door	C Depth - door open 90°	D Depth-Cutting Board	E Height - Lid Open at 70 Degrees	Clear door opening	# of doors	# of shelves per cabinet	Total shelf area sq. ft.
KUST276	7.1	6	27"	25 7/8"	55 3/8"	12"	16 1/4"	22 3/4"	1	2	4.88
KUST279	7.1	9	27"	25 7/8"	55 3/8"	8"	22 3/16"	22 3/4"	1	2	4.88
KUST328	8.8	8	32"	30 13/16"	60 3/8"	12"	17 1/2"	27 3/4"	1	2	6.13
KUST3212	8.8	12	32"	30 13/16"	60 3/8"	8"	23 5/8"	27 3/4"	1	2	6.13
KUST488	13.1	8	48"	21 1/8"	50 5/8"	12"	16 1/4"	18"	2	4	10.3
KUST4812	13.1	12	48"	21 1/8"	50 5/8"	12"	16 1/4"	18"	2	4	10.3
KUST4818	13.1	18	48"	21 1/8"	50 5/8"	8"	23 3/4"	18"	2	4	10.3
KUST6012	16.7	12	60"	25 7/8"	55 3/8"	12"	16 1/4"	22 3/4"	2	4	13.2
KUST6024	16.7	24	60"	25 7/8"	55 3/8"	8"	23 3/4"	22 3/4"	2	4	13.2
KUST7212	20	12	72"	25 7/8"	60 3/8"	12"	16 1/4"	27 3/4"	2	4	15.5
KUST7218	20	18	72"	30 13/16"	60 3/8"	8"	23 3/4"	27 3/4"	2	4	15.5
KUST7224	20	24	72"	30 13/16"	60 3/8"	8"	23 3/4"	27 3/4"	2	4	15.5
KUST7230	20	30	72"	30 13/16"	60 3/8"	8"	23 3/4"	27 3/4"	2	4	15.5

Top Pan Configuration

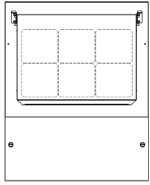

KUST276 Model

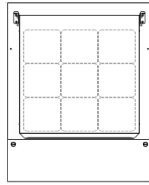

KUST279 Model

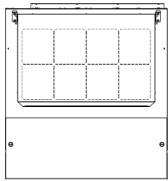

KUST328 Model

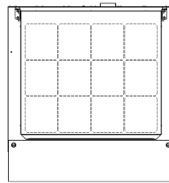

KUST3212 Model

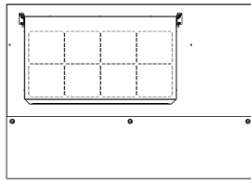

KUST488 Model

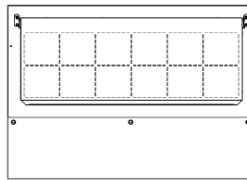

KUST4812 Model

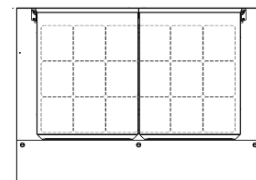

KUST4818 Model

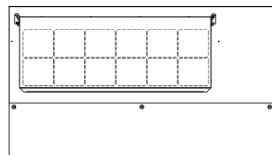

KUST6012 Model

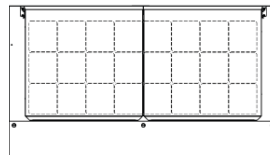

KUST6024 Model

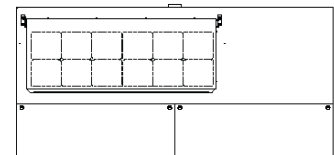

KUST7212 Model

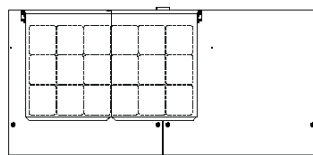

KUST7218 Model

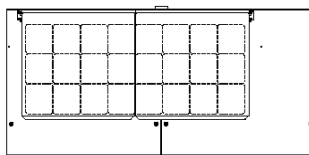

KUST7224 Model

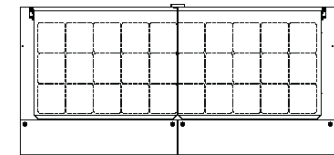

KUST7230 Model

Specifications

Construction, Hardware and Insulation

Cabinet exterior front, one piece sides, pan lid, and doors are constructed of 22 gauge stainless steel. Cabinet interior and door liners are constructed of anodized aluminum. The exterior cabinet back and bottom are constructed of galvanized steel.

Doors self close at less than 90 degrees and also includes a stay open feature at 105 degrees. Easily removable for cleaning, vinyl magnetic door gasket assures tight door seal.

Both the cabinet and doors are insulated with an average of 2" thick high density, non-CFC, foamed in place polyurethane.

A 3/4" thick, full-length, reversible white nylon cutting board is supplied standard.

Pans & Cover

Each model is supplied standard with its full compliment of 4" deep plastic 1/6 size pans and stainless steel pan dividers. The insulated lift-up pan cover is constructed of stainless steel, and is easily removable for cleaning.

Refrigeration System

A balanced, rear mounted, front breathing, self-contained refrigeration system using R-134a refrigerant is provided. It features a capillary tube metering device, air-cooled hermetic compressor, a forced air evaporator coil and a non-electric condensate evaporator. An 8' cord and plug is provided. Standard operating temperature of the refrigerated base is 34 to 38°F.

Interior

Standard interior arrangements include two (2) powder coated wire shelves per door, mounted on pilasters. These are adjustable in 1/2" increments, allowing for a minimum of 1-1/2" spacing between shelves.

Warranties

Both a three year parts and labor warranty and a five year compressor warranty (self-contained models only) are provided standard.

Electrical & Refrigeration Data 115/60/1 R-134a NEMA 5-15P			Shipping Data (42"D x 41"H)		
Model	Full Load Amps	BTU/HR - HP	Width - crated	Volume - crated cu. ft.	Weight - lbs.
KUST276	4.7	1020 (1/5 HP)	45"	45	376 net/425 gross
KUST279	4.7	1020 (1/5 HP)	45"	45	376 net/425 gross
KUST328	6.2	1020 (1/5 HP)	45"	45	255 net/300 gross
KUST3212	6.2	1020 (1/5 HP)	45"	45	255 net/300 gross
KUST488	5.5	1600 (1/4 HP)	69"	69	355 net/400 gross
KUST4812	5.5	1600 (1/4 HP)	69"	69	355 net/400 gross
KUST4818	5.5	1600 (1/4 HP)	69"	69	355 net/400 gross
KUST6012	5.5	1600 (1/4 HP)	69"	69	457 net/500 gross
KUST6024	5.5	1600 (1/4 HP)	69"	69	457 net/500 gross
KUST7212	6.3	1600 (1/4 HP)	84"	84	548 net/575 gross
KUST7218	6.3	1600 (1/4 HP)	84"	84	548 net/575 gross
KUST7224	6.3	1600 (1/4 HP)	84"	84	548 net/575 gross
KUST7230	6.3	1600 (1/4 HP)	84"	84	548 net/575 gross

NOTES:

- Overall depth figure includes standard cutting board.
- Height shown when mounted on 6" high legs or casters.
- Based on a 90 degree F ambient and 20 degree F evaporator.
- When ordering please specify: Voltage, Hinging, Optional Accessories and any additional warranties.
- Continued product development may necessitate specification changes without notice.